

Doherty Power Amplifier Circuit

Communications & Information

Digital Broadcasting, Telecommunication and Optoelectronics

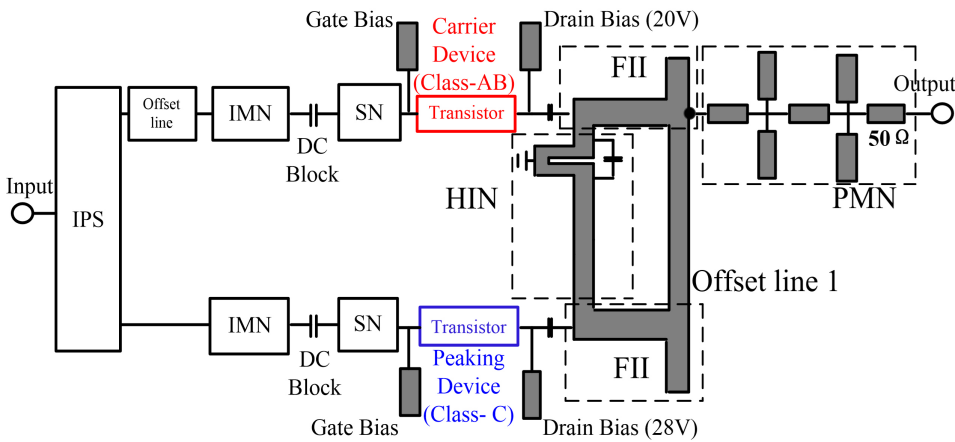

IP Status

Patent granted



Technology Readiness Level (TRL) ?

6

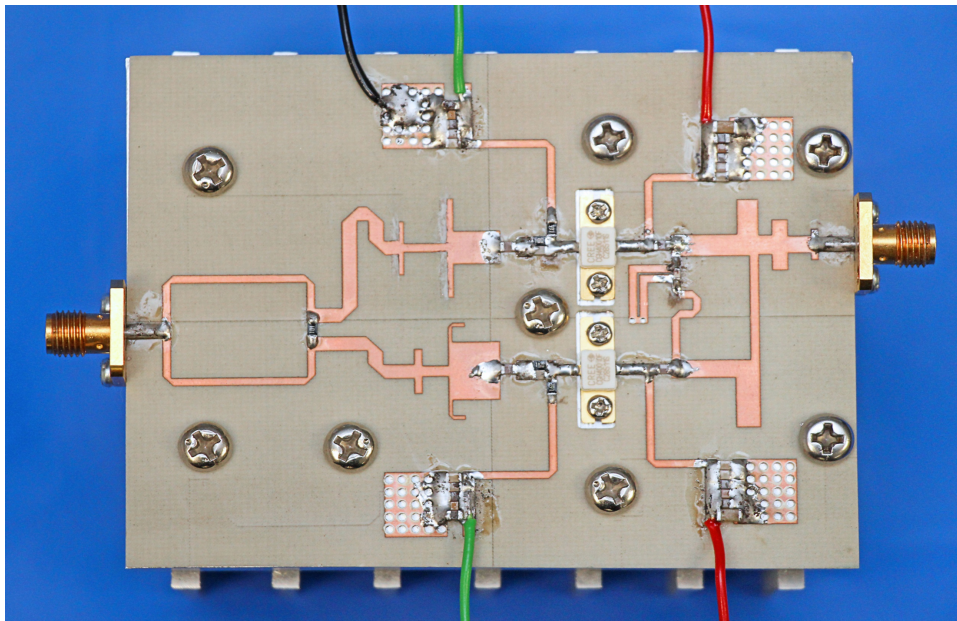

Inventor(s)

Prof. CHAN Wing Shing

Prof. HO Derek

Dr. ZHOU Xinyu

Dr. ZHENG Shaoyong

Mr. FANG Xiaohu

Enquiry: kto@cityu.edu.hk

Opportunity

In modern and future wireless communication systems, the use of more spectrally efficient modulated signals with high peak to average power ratios are used. These signals causes a large variation in the instantaneous output power. Radio frequency (RF) power amplifiers in base stations of these wireless communication systems are required to maintain high efficiency over a larger dynamic range which is a challenge. With 5G Mobile Radio already upon us, in the near future we will see further expansion in the number of base stations that use smaller cell sizes. It is envisaged that there will be an increase in the number of base stations by 5-10 times. With such a large increase there is a need for more efficient RF power amplifiers.

Develop Concept

Proof Concept

Build Value

Follow-up Training

Technology

The technology is based around the Doherty topology which has seen a resurgence in recent years. This topology is used in most base stations because of its efficiency even with the more spectrally efficient modulation formats that have a high peak to average power ratio of 6dB. The invention here is based on a new method of harmonic injection that uses a new harmonic injection network (HIN) to significantly improve the efficiency. This is achieved by inserting an additional path for the harmonic that allows for wideband operation and with a larger output dynamic range of 9dB. This larger output dynamic range is necessary for present and future 5G base stations.

Advantages

- High Efficiency
- Broad Bandwidth

Applications

- Mobile Radio Base Station
- Broadcasting

