

A novel distributed system for plasma immersion ion implanter control and automation

A. G. Liu, X. F. Wang, B. Y. Tang, and P. K. Chu^{a)}

Department of Physics and Material Science, City University of Hong Kong, 83 Tat Chee Avenue, Kowloon, Hong Kong

P. K. Ko

School of Engineering, Hong Kong University of Science & Technology, Clear Water Bay, Kowloon, Hong Kong

Y. C. Cheng

Hong Kong University, Pokfulam Road, Hong Kong

(Received 3 December 1997; accepted for publication 10 December 1997)

The high voltage and electromagnetic field environment poses a big challenge to a control system for plasma immersion ion implantation (PIII). The automation process must be immune to electric field interference produced by the high voltage power supply, modulator, radio-frequency or microwave plasma generator, MEVVA plasma sources, and so on. We have recently designed and installed a distributed control system, PIIIDCS, to automate the operation of our PIII facility. Programmable logic controllers are used as the field control stations because of their good anti-interference ability and good real time response. A DH-485 network is used as the communication link between the field controllers and the management station in order to improve the robustness and reliability of the system. The newly developed interface is designed to work in a graphic mode in Microsoft Windows 95. Test runs have shown that the system is reliable, flexible, and easy to operate. The development of this novel control system will expedite the development of commercial PIII instrumentation. © 1998 American Institute of Physics.

[S0034-6748(98)03703-4]

I. INTRODUCTION

The ever-increasing demands by the materials industry to improve materials surface properties have translated into an unprecedented development in surface modification technology. Plasma immersion ion implantation (PIII), demonstrated by Conrad *et al.* in the late 1980's,¹ is showing great commercial potential in the fields of metallurgy, surface modification, as well as semiconductor processing.² In PIII, ions generated by a plasma source are accelerated by a negative voltage applied to the sample and implanted conformally into the target. The high voltage and associated electric field from the plasma generators, especially the radio-frequency plasma source and MEVVA plasma sources, cause strong interferences to electronics and impose a big challenge for a control and automation system for PIII. Existing PIII facilities are usually equipped with relatively crude control systems, and most of them are even manually controlled.² The lack of a robust and reliable control system is a formidable obstacle for the commercialization of PIII.

The simplest PIII control system includes a single computer to accomplish all the tasks such as data collection, data management, data logging, control logic management, computation, and so on. All the field points are usually connected to the computer I/O interface by cables that can be very long

when the field points are far from the computer, and such a system is thus prone to electromagnetic field interference. It can be so serious that the system does not work properly or even gets damaged if large analog signals find their way into the system via the long cables. The system is also constrained by the I/O ability of the computer, and signal loss in the long cables can be substantial. Hence, the higher the level of integration, the more serious is the interference problem. Such a simple system cannot be expanded easily to accommodate larger systems and so it is not suitable for commercial PIII equipment. We have recently developed a new distributed control system, PIIIDCS, to automate the PIII facility in the City University of Hong Kong.^{3,4} The introduction of the concept of DCS has greatly improved the reliability and the robustness of the system.

II. SYSTEM STRUCTURE

In order to overcome the shortcomings of common PIII control systems and improve the efficiency, a distributed control system, PIIIDCS, has been developed. The schematic of PIIIDCS is depicted in Fig. 1. The PIIIDCS system can be divided into three parts: field controllers, communication network, as well as operation and management station. The field controllers collect data from the field and carry out control commands. The operation and management station is responsible for data logging, system status monitoring, and failure warning, and is the main machine interface. The com-

^{a)}The author to whom correspondence should be addressed; electronic mail: apkchu@cityu.edu.hk

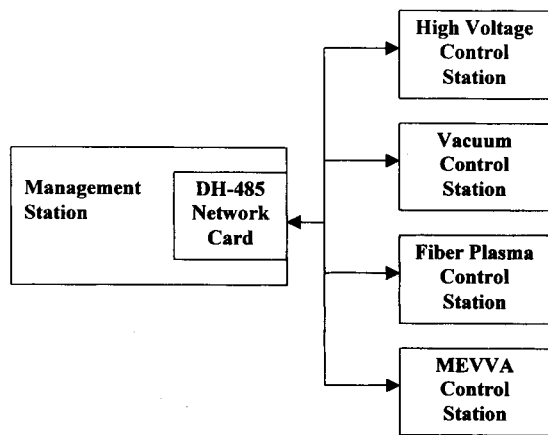

FIG. 1. Schematic of PIIDCS.

munication network provides the data transfer channels between the management station and the controllers.

With this setup, the field controllers in lieu of the central computer are responsible for the data collection and instrument control. The field controllers can be arranged according to the distribution of the field points to make the cable as short as possible. Communication between the controllers and management station is accomplished by serial signals that are insensitive to electromagnetic interference. This arrangement therefore alleviates the interference problem caused by analog signals inadvertently getting into the system. The effectiveness of such a system only depends on the performance of the field controllers, the management station, and the network.

III. PIIDCS FIELD CONTROLLERS

A. Hardware selection

Field controllers carry out the control tasks of the PIIDCS system. These are the most vulnerable parts of the system to interference, and in order to satisfy the anti-interference and quick response requirements, they must be arranged as close to the field points as possible. Special consideration must also be considered to take in account real time operation as the controllers must handle communication functions. Based on these requirements and the characteristics of PIII equipment, programmable logic controller (PLC) is a good choice as the field controller. Due to the scale of the system, SLC500 series products from Allen-Bradley are selected. The products are designed with special anti-interference consideration and function properly in a high field environment. As all the hardware is modular, expansion can be readily implemented. The 1747-L524 CPU mode with built-in 4k RAM can process as many as 480 discrete I/O points. It is compatible with many digital and analog I/O modules, and provides DH-485 and DH+ network communication interface.

B. Software design

The four field controllers in the system are responsible for different control tasks, but to some degree, their functions are similar. The main operations are sequential control, con-

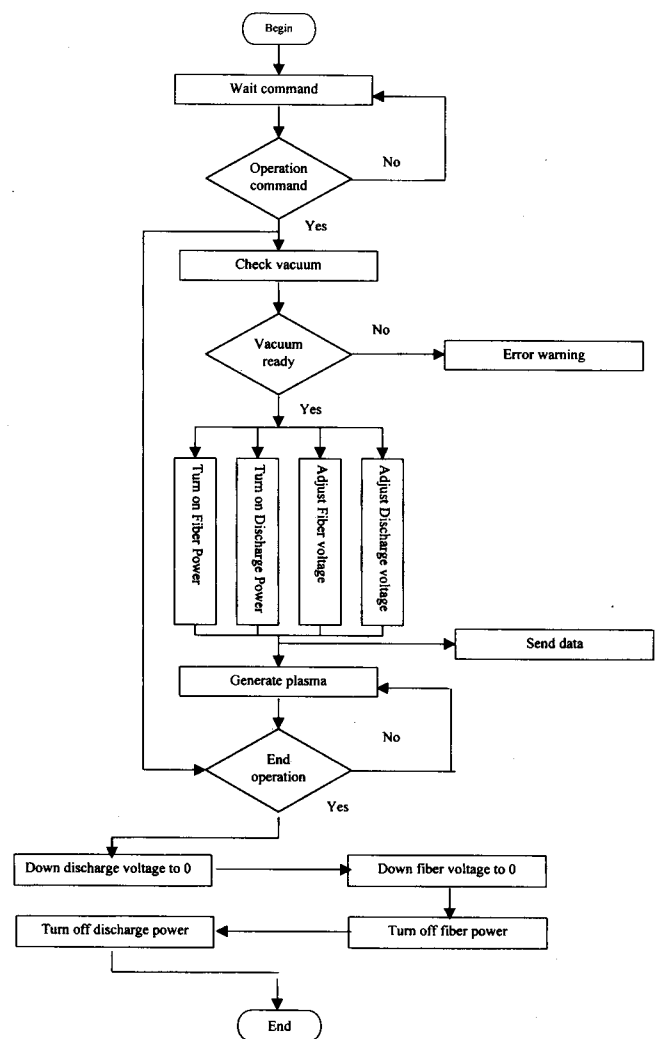

FIG. 2. Flow chart of the fiber plasma control program.

tinuous control, data collection, data transmission, failure/error warning to the management station, and communication among each other. As an example, the flow chart of the fiber plasma source controller program is displayed in Fig. 2. When the program is executed, the controller waits for an operation command for the management station. If it is anything other than "END OPERATION," the controller will check the vacuum data sent by the vacuum controller. If the pressure is within the working range, the controller will carry out the operation command, and the plasma will be ignited automatically. The voltage and current data will be sent to the management station via the network. If the pressure is out of the working range, the controller will send an error message to the management station. If the operation command is "END OPERATION," the controller will execute the stop procedure and shut down the fiber plasma source.

IV. COMMUNICATION NETWORK

A very important characteristic of PIIDCS is that it makes use of a network to carry the communication signals instead of employing control cables to carry the control signals. This is one of the anti-interference considerations. The performance of the network will determine whether the con-

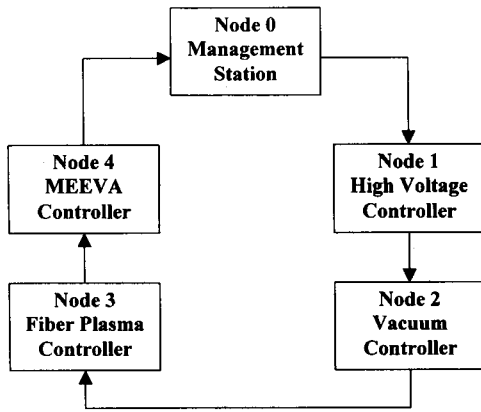

FIG. 3. Logic structure of PIIDCS.

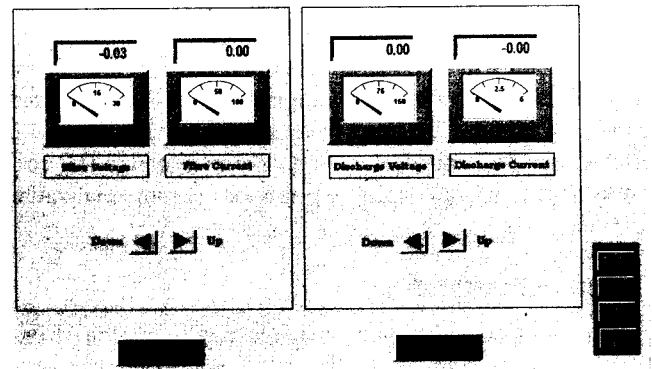

FIG. 4. User interface of fiber plasma source.

troller can get the control command sent by the management station in time, whether the management station can get the data and failure warning from the controllers correctly, and whether the controllers will work in a synchronous way. In order to make the system more robust in an industrial environment, a serial communication standard, DH-485 protocol, that is consistent with RS-485 on the physical layer, is used to construct the network. This protocol can support 32 nodes in the network, and the maximum transmission distance can reach 1219 meters. Twist-pair cables are used to transmit signals in a differential way. Consequently, high interference resistance can be achieved at a low cost.

For medium access, the token ring method is used because maximum transmission time can be given to all token passing procedures, and priority schemes are very easy to implement. Such procedures are more suitable for real time applications than CSMA/CD.⁵

Though the topology structure of the PIIDCS is that of a bus pattern, the logic structure is of a ring pattern as shown in Fig. 3. The nodes on the net are divided into two kinds, the transmitters and the receivers. When the network is running, any transmitter can send valid packets onto the net. To determine which is the authorized transmitter, a token is needed. During network initialization, the management station which is assigned the lowest address holds the token initially and performs the network establishment procedure which begins when the management station starts sending the token to the successive node. If the trial fails, it begins a linear search for the higher addresses until another node is found, and the token is sent to this node. The procedure is repeated until the token returns to the management station. In a normal operation, the token holder sends the data packets to the network. In PIIDCS, there are not a lot of data to transmit, but the data are sent very frequently to each controller. Packets are transmitted only when the controller catches the token and the token is subsequently sent to the next node. If no data are to be transmitted, the token is sent to the next node directly.

V. MANAGEMENT STATION

Although the controllers can accomplish data collection and control tasks efficiently according the preset program, it

is difficult for the operator to vary the process while it is running. Fortunately, the management station of PIIDCS provides functions such as control and adjustment, animation, flow charts, historical records, warning, and printing. These tasks can be accomplished quite effectively with a personal computer. Even though a personal computer has very poor interference resistance, the network can provide the long distance connections to the management station, and so that interference is not a problem for the distant management station.

For convenience of operation, the operator interface is designed to run in a graphic mode under Microsoft Windows 95. As an example, the user interface of the fiber plasma source is exhibited in Fig. 4. The FIBER POWER button and DISCHARGE POWER button are related to bits b3:0/0 and b3:0/3 in the fiber plasma source controller through the communication driver. When the power is off, the button is green. The power will come on if the button is pressed using the mouse, and the button turns to red. Power will be turned off if the red button is triggered.

The fiber voltage, fiber current, discharge voltage, and discharge current are measured using sensors and sent to the CPU of the controller after A/D conversion. Scaling of the signal is done in the controller, and the scaled data are transmitted to the management station via the network. The data are displayed on the monitor screen in digital and/or analog form for accurate visual assessment. New data are sent to the management station continuously, and the screen refreshes in real time. The flow chart of the fiber voltage signal is shown in Fig. 5.

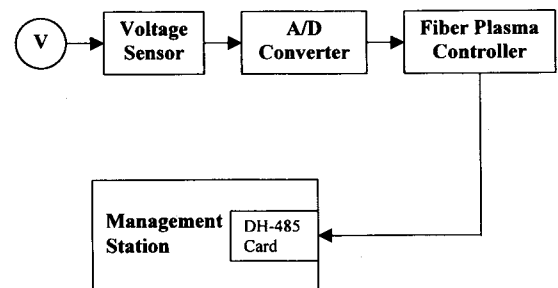

FIG. 5. Flow chart of fiber voltage signal in the system.

VI. DISCUSSION

A novel distributed control system, PIIDCS, is designed and installed to operate PIII equipment to circumvent interference problems. Test runs have shown that the system is reliable, flexible, expandable, and easy to operate. The control system is an important step towards commercialization of PIII.

ACKNOWLEDGMENTS

The work is supported by City University of Hong Kong Strategic Grant No. 7000730 and Hong Kong Research

Grants Council Grants No. 8730005, No. 9040220, and No. 9040332.

¹J. R. Conrad, J. L. Radtke, R. A. Dodd, F. J. Worzala, and N. C. Tran, *J. Appl. Phys.* **62**, 4591 (1987).

²P. K. Chu, S. Qin, C. Chan, N. W. Cheung, and L. A. Larson, *Mater. Sci. Eng. R. Rep.* **R17**, 207 (1996).

³P. K. Chu, B. Y. Tang, Y. C. Cheng, and P. K. Ko, *Rev. Sci. Instrum.* **68**, 1866 (1997).

⁴P. K. Chu, S. Qin, C. Chan, N. W. Cheung, and P. K. Ko, *IEEE Trans. Plasma Sci.* (to be published).

⁵Hans-Georg Gohring and Franz-Joachim Kauffels, *Token Ring* (Addison-Wesley, Reading, MA, 1992).